



TECHNO-PIEUX, INC.
1700 Setlakwe Street
Thetford Mines, Quebec, Canada G8G 8B2
(418) 334-2023
www.technometalpost.com/en-US/

TECHNO METAL POST HELICAL FOUNDATIONS

CSI Section:

- 31 66 00 Special Foundations**
- 31 66 15 Helical Foundation Piles**

1.0 RECOGNITION

Techno Metal Post Helical Foundations manufactured by Techno-Pieux, Inc., have been evaluated for use as load-bearing foundation elements. The physical, structural, and durability characteristics and the manufacturing and installation methods of the Helical Foundations were evaluated. The Helical Foundations are recognized for use as alternatives to prescriptive foundations and footings for decks and other residential accessory structures, and new construction and additions for residential occupancies built under the following codes:

- 2021, 2018, 2015, and 2012 International Residential Code® (IRC)

2.0 LIMITATIONS

Use of the Techno Metal Post Helical Foundations recognized in this report is subject to the following limitations:

2.1 Use of Techno Metal Post (TMP) Helical Foundations shall comply with the provisions of the applicable codes, the manufacturer’s published installation instructions, and this report. Where conflicts occur in these provisions, the most restrictive shall govern.

2.2 TMP Helical Foundations are for use in seismic design category (SDC) A, B, or C locations, except that Helical Foundations are recognized for use in SDC D₀, D₁, or D₂ locations as described in Section 3.1.6 of this report to support light-frame residential decks and accessory structures such as porch covers, gazebos, and pergolas. Helical Foundations for other applications in SDC D₀, D₁, or D₂ locations, or for use in SDC E locations, are outside the scope of this report and require design per IBC.

2.3 The building official may require a soil test where the presence of questionable soil characteristics such as expansive, compressible, liquifiable, or shifting soils is likely based on quantifiable data in accordance with IRC Section R401.4.

2.4 Allowable lateral load resistance capacities of the Helical Foundations have not been evaluated and shall be determined by a registered design professional in a manner acceptable to the building official.

2.5 The capacity of the supported structure to transfer the design loads to the Helical Foundations is outside the scope of this report.

2.6 The Helical Foundations recognized in this report are produced by Techno-Pieux, Inc., in Thetford Mines, Quebec, Canada.

3.0 PRODUCT USE

3.1 Design: The design loads applicable to each Helical Foundation device shall be determined in accordance with the code for the building location and portion of the building supported. The Helical Foundation components shall be selected based on their tabulated capacity to support the design loads, and interconnected to transfer the loads from the supported structure through the load path to the bearing strata. The Helical Foundations shall be installed using the appropriate torque in accordance with the allowable axial geotechnical capacity formula in Section 3.1.1, using the applicable Safety Factors in Section 3.1.2 of this report.

Where engineered design is required, the Allowable Stress Design (ASD) method shall be used, considering all applicable limit states. The designs shall be prepared by a registered design professional where required by the statutes of the jurisdiction in which the project is constructed, and submitted to the building official for approval. The likely effects of corrosion shall be considered, and adequate sacrificial material shall be provided to maintain Helical Foundation support capacity (the shaft shall not lose more than 33 percent of its required design base metal thickness) for a 50-year projected service life of the Helical Foundation.

3.1.1 Helical Foundation Geotechnical Capacity Based on Installation Torque: The maximum axial geotechnical compression and tension capacities of the Helical Foundations shall be limited to the capacities established by applying the torque-to-capacity ratio and the applicable factors of safety to the final torque reached during installation in accordance with the allowable axial geotechnical capacity formula shown below. The model of Helical Foundation shall be selected so that the tabulated maximum allowable capacity is sufficient to support the design load. Installation shall be accomplished without exceeding the rated torque capacity established by testing, to prevent damage to the assembly. The maximum rated torque correlates to the Helical Foundation maximum geotechnical axial capacities shown in Table 1 of this report.

The product described in this Uniform Evaluation Service (UES) Report has been evaluated as an alternative material, design or method of construction in order to satisfy and comply with the intent of the provision of the code, as noted in this report, and for at least equivalence to that prescribed in the code in quality, strength, effectiveness, fire resistance, durability and safety, as applicable, in accordance with IBC Section 104.11. This document shall only be reproduced in its entirety.





Allowable axial geotechnical capacity, $P_a = P_u / SF$
where;

P_u = Ultimate bearing capacity = $K_t \times T$ (lb)

SF = Applicable factor of safety

K_t = Torque-to-capacity ratio given in Table 1 (ft⁻¹)

T = Torque applied during installation (lb-ft)

3.1.2 Factors of Safety: Appropriate Factors of Safety (SF) for use in the allowable axial geotechnical capacity formula in Section 3.1.1 of this report, are chosen based on the type of structure to be supported, the availability of a soil report, and the direction of loading. Appropriate factors of safety have been applied to the values tabulated in this report.

- For deck support in accordance with Section 3.1.6 of this report, including in SDC D₀, D₁, and D₂, a Safety Factor of 2.0 is used for compression.
- For residential accessory light-frame structures with an area of 600 square feet or less and an eave height of 10 feet or less, a SF of 2.0 may be used for compression.
- Where a soil test is available and the soil is considered adequate, a minimum SF of 2.0 may be used.
- For main structures in applications where a soil test is not available, a minimum SF of 2.5 is used for axial compression.
- For geotechnical tension capacity determination, a minimum SF of 2.5 shall be used.

3.1.3 Support Capacity Based on Column Design: The structural column capacities are given in Table 2 and are subject to the limitations described in the notes to that table. Helical Foundation shafts in fluid soils or when exposed more than 6 inch above grade, shall be designed as axially loaded columns using appropriate engineering standards in accordance with the IBC.

3.1.4 Capacity of Helical Foundations Loaded in Tension: Helical Foundations may be used to resist design axial tension loads. The allowable axial tension capacity shall be determined based on installation torque and, when applicable, shall be limited to the weight of soil above the helix. In either case, the allowable capacity shall not exceed the structural tension capacity of the assembly given in Table 2 of this report. Where the depth of the helix plate is at least twelve times the helix diameter (12D), the axial tension capacity may be based solely on the allowable axial geotechnical capacity formula in Section 3.1.1 of this report, using a SF of 2.5, minimum.

Where Helical Foundations are installed at depths less than 12D, shallow pull-out failure shall be avoided by further limiting the foundation tension capacity to the weight of the soil cone over the helix as depicted in Figure 2 of this report. The weight of a soil cone based on density and saturation is given in Table 4 of this report assuming an angle of 30 degrees.

3.1.5 Helical Foundations Limited by Cap or Bracket Capacity: Helical Foundations shall be limited to the

capacity of the cap or bracket connected to the top of the Helical Foundation shaft and supporting the load from the structure. An appropriate cap or bracket for the support situation shall be designed or chosen to transfer the load from the structure into the Helical Foundation. Underpinning bracket allowable capacity shall be limited to the values in Table 5 of this report.

3.1.6 Deck Support: Helical Foundations are recognized for use as alternatives to the footings prescribed in IRC Section R507.3 to support decks. Helical Foundation Models P1, P2, or P3 may be used in accordance with Table 3 of this report to replace footings in the sizes prescribed in IRC Table R507.3.1 for the given support conditions. All other requirements in the IRC still apply. Connection of the decks to the shafts of the Helical Foundations is outside the scope of this report, and shall be justified to the satisfaction of the building official.

3.1.7 Capacity of Helical Foundations Based on Field Testing: When the use of Helical Foundations falls outside the limitations of this evaluation report, or when capacities are in doubt, field testing may be used to determine the capacity of the Helical Foundation systems. Where field tests are required to confirm the capacity of a Helical Foundation installation, these tests shall be supervised by a registered design professional.

3.2 Installation: The Helical Foundations shall be installed by personnel trained and approved by the Helical Foundation system manufacturer using manufacturer-approved equipment specially designed to drive the Helical Foundations into the ground using measurable downward and rotational force. The equipment shall be calibrated yearly or as necessary to validate the relationship between hydraulic pressure and installation torque. The installer's certification and the equipment certificate of calibration shall be presented to the building official upon request.

In the absence of data indicating the presence of questionable soils, and unless the building official determines that a soil test is required, the Helical Foundations shall be installed in undisturbed soil or engineered fill using the Helical Foundation's torque-to-capacity ratio and appropriate factors of safety to determine their geotechnical capacities. Helical Foundation installation shall continue until the appropriate installation torque is reached, indicating that the Helical Foundation has achieved the desired bearing capacity. The torque applied to a Helical Foundation during installation shall never exceed the maximum rated torque in accordance with Table 1 of this report. Installation shall also continue until bearing plates reach below the frost line, and to a minimum depth not less than 4 feet (1219 mm) for Helical Foundations loaded in compression. For Helical Foundations loaded in tension, the depth shall be sufficient to avoid a shallow pull-out failure as shown in Table 4.

The spacing between Helical Foundations (center to center of pile shaft) shall be minimum 3 times the diameter of the



largest helix in adjacent Helical Foundations. The foundation shaft shall be within 0.35 degrees of vertical (or 1/2 inch in 7 feet) when installation is complete. Adequate drainage shall be provided directing water away from the foundation support locations. Where Helical Foundations are installed on or adjacent to slopes, the negative effects of drainage, erosion, and shallow failures shall be avoided in accordance with IRC Section R403.1.7.

3.2.1 Extensions: For the P2 and P3 Helical Foundations, extensions shall be added as necessary to reach the desired depth of bearing strata. Extensions for the P1 Helical Foundations are outside the scope of this evaluation. The extensions shall be field welded in accordance with AWS D1.1-20, using a continuous weld around the shafts at the joints between the extension couplers and the Helical Foundation shafts being extended (see Figure 1). The welds shall be 3/16-inch (4.76 mm) fillet welds for the P2 and 1/4-inch (6.35 mm) fillet welds for the P3 Helical Foundations. The torque applied to install each extended Helical Foundation provides an effective proof test with a built-in safety factor for these field-welded extensions, up to the installed geotechnical capacity of the Helical Foundation.

3.2.2 Caps or Brackets: Once adequate depth and bearing capacity are reached, the shaft shall be cut off and an appropriate cap or bracket shall be selected from Table 5 or designed, and installed to transfer the supported load to the Helical Foundation. The cap or bracket shall be adequately anchored to the top of the Helical Foundation using bolts, welds, screws, or otherwise attached to the shaft and to the supported structure above so that the Helical Foundation is concentrically axially loaded in accordance with the design. For remedial foundation work, an underpinning bracket (Figures 3A, 3B, 3C, and Table 5 of this report) may be used that imposes an eccentric load on the Helical Foundations in accordance with the design.

3.2.3 Field Reports: A Helical Foundation installation log shall be prepared to describe the installation results and safe geotechnical (bearing) capacities for each foundation shall be determined from the data acquired during installation. Trained, certified installers shall record all foundation locations and types including shaft diameters, helix sizes, embedment depths, heights of the top of the piles, calculations supporting the substitution of piles or footings in accordance with table 3 and final torque readings. In addition, a torque profile shall be recorded for every job, and at least one out of every ten piles in multi-pile installations.

A field report containing this information, along with the type of project, relevant details of the supported structure, sketch or drawing of the support situation with dimensions, the types of Helical Foundation caps or brackets used, and the connection of these to the Helical Foundation and the supported structure. The allowable geotechnical capacity based on torque-to-capacity ratio shall be reviewed by a registered design professional. The report shall be submitted

to the building official for approval within 10 days after Helical Foundation installation.

4.0 PRODUCT DESCRIPTION

Techno Metal Post Helical Foundations are foundation devices consisting of steel HSS columns with helical bearing plates welded near their base. The devices are installed in accordance with this report to transfer structural loads into the underlying support strata. Extensions are added to the shafts using couplers to allow the bearing plates to reach deeper bearing strata when necessary. The shafts and extensions for Techno Metal Post Helical Foundations are made from ASTM A500 Grade C steel shafts having a yield strength of 51 ksi (352 MPa) minimum, and shaft diameters and thicknesses shown in Table 1. The helical bearing plates are made from steel plate material, having a yield strength of 44 ksi and tensile strength of 65 ksi (303 MPa and 448 MPa), minimum, and are 3/8-inch-thick (9.53 mm) for the P1 and P2 Helical Foundations, and 1/2-inch-thick (12.7 mm) for the P3 Helical Foundations. The plates are formed to a standard helical pitch of 3 inches. The plates are factory welded to the shafts in accordance with the manufacturer's quality control system specifications.

The tops of the shafts are connected to the supported structure using caps or brackets. An adjustable underpinning bracket is available to provide a shelf to support existing structures for remedial foundation work. The underpinning brackets are made from steel having a yield strength of 44 ksi and tensile strength of 65 ksi (303 MPa and 448 MPa), minimum. The caps and brackets are connected to the shafts in accordance with an engineered design using appropriate standards and practices. The assemblies may be of bare steel or hot-dip galvanized in accordance with the job requirements.

5.0 IDENTIFICATION

Techno Metal Post Helical Foundations are identified by the Techno-Pieux, Inc. name and trademark, model name, and evaluation report number (ER-481). The identification also includes the IAPMO Uniform Evaluation Service Mark of Conformity. Either Mark of Conformity may be used as follows:

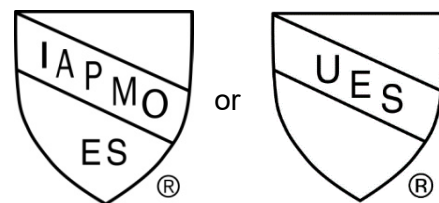

IAPMO UES ER-481



6.0 SUBSTANTIATING DATA

- 6.1 Documentation in accordance with IAPMO-UES Evaluation Criteria for Helical Foundations for Use under the IRC, EC 027-2019.
- 6.2 Reports of field testing to establish Torque-to-Capacity Ratio for each Helical Foundation model.
- 6.3 Test reports are from laboratories in compliance with ISO/IEC 17025.
- 6.4 Engineering analysis.

7.0 STATEMENT OF RECOGNITION

This evaluation report describes the results of research completed by IAPMO Uniform Evaluation Service on Techno Metal Post Helical Foundations to assess their conformance to the codes shown in Section 1.0 of this report and documents the product's certification. The Techno Metal Post Helical Foundations are produced at locations noted in Section 2.6 of this report under a quality control program with periodic inspection under the supervision of IAPMO UES.

For additional information about this evaluation report please visit www.uniform-es.org or email at info@uniform-es.org

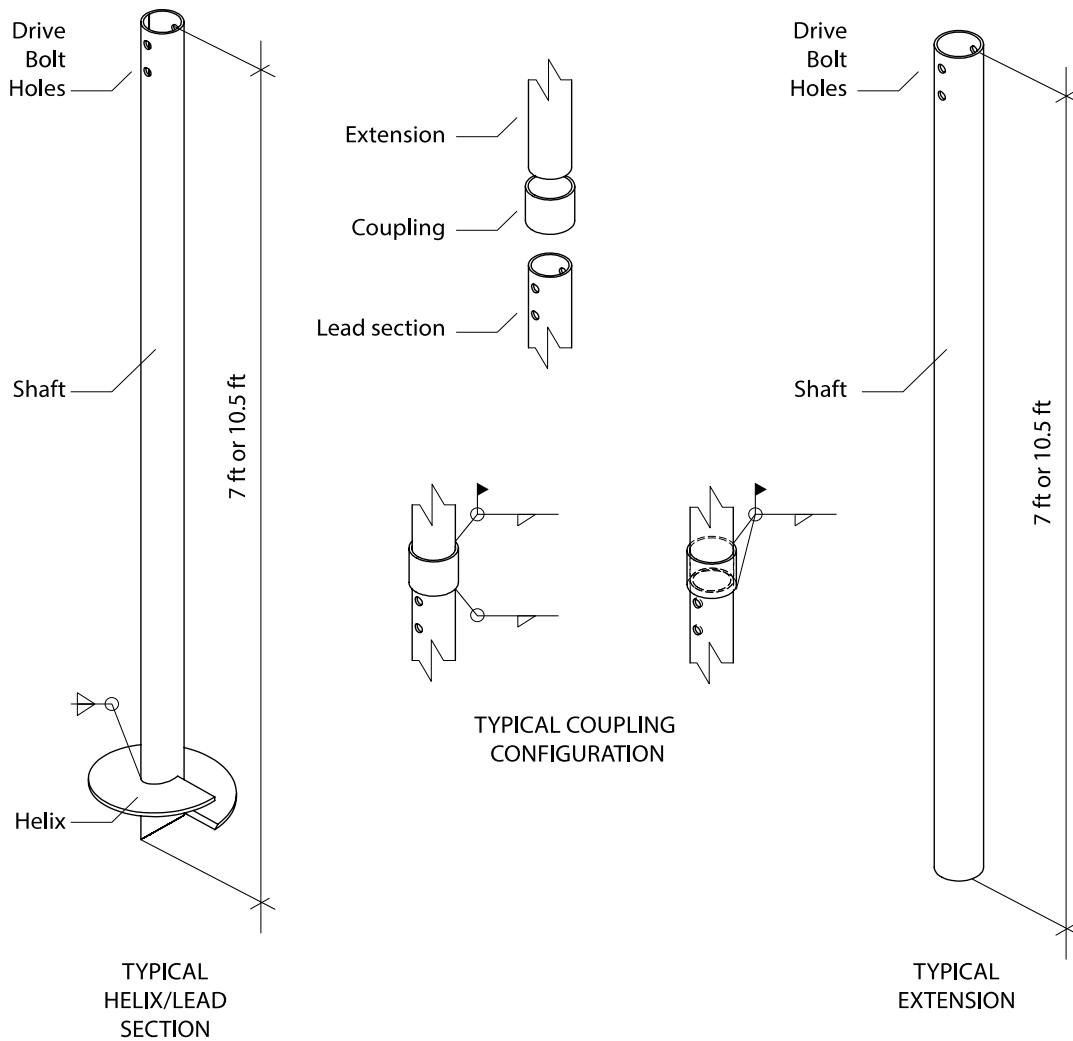

(FIGURE 1 – Basic Helical Assembly)



TABLE 1 – HELICAL FOUNDATION DIMENSIONS AND GEOTECHNICAL CAPACITIES BY MODEL NUMBER

Model ¹	Helix Diameter (in)	Shaft Outer Diameter (in)	Nominal Shaft Thickness (in)	Maximum Rated Torque (ft-lbf)	Torque-to-capacity Ratio (K _t)	Maximum Allowable Axial GEOTECHNICAL Capacity (lbf) ²		
						SF=2	SF=2.5	SF=3
P1-6	6	1 7/8	0.145	1,336	10	6,679	5,344	4,453
P1-8	8							
P1-10	10							
P1-12	12							
P2-8	8	2 3/8	0.154	2,242	10	11,210	8,968	7,473
P2-10	10							
P2-12	12							
P2-16	16							
P3-8	8	3 1/2	0.216	8,509	7	29,782	23,825	19,854
P3-10	10							
P3-12	12							

S.I.: 1 inch = 25.4 mm; 1 ft-lbf = 1.4 N-m; 1 lbf = 4.4 N

- Helical Foundations are available in bare steel or hot-dip galvanized steel.
- The maximum allowable axial geotechnical capacities were determined by testing to establish the maximum torque rating and the torque-to-capacity ratio coefficient, K_t. The allowable capacities include a safety factor (SF) as shown.
- Allowable axial tension loading shall consider the possible shallow pull-out failure. Twelve times the helix diameter (12D) shall be sufficient to develop the tension capacities tabulated. Depths less than 12D shall consider and be limited to the weight of soil above the helix.

TABLE 2 – ALLOWABLE STRUCTURAL CAPACITIES BY HELICAL FOUNDATION MODEL NUMBER

In Firm Soils ^{2,4}			In Soft Soils ^{2,4}		
P1	P2	P3	P1	P2	P3
Allowable Compression Capacity – Braced Head (lbf)^{1,3,5}					
6,900	11,600	32,200	3,000	5,900	22,300
Allowable Compression Capacity – Free Head (lbf)^{1,3,5}					
3,000	6,500	20,000	Design Required		

Allowable Tension Capacity (lbf)^{1,5,6}					
P1	P2	P3	P1	P2	P3
12,900	18,800	43,300			

S.I.: 1 lbf = 4.4 N

- Geotechnical bearing capacity (i.e. installation torque) may control.
- Firm soils are defined as any soil type which complies with IRC Table 401.4.1. Sites with fill, very soft or compressible soils, expansive soils, or other deleterious conditions shall have site specific engineering review. As needed, firm soils may also be verified by installing a P2 shaft with a single 16-inch helix and measuring torque as the pile advances. If the average installation torque equals or exceeds 800 ft-lb in the top five feet, the soil may be deemed firm. Alternatively, any soil with a blow count of N=4 or greater may also be deemed firm.
- A braced head condition is defined as a TMP that is braced laterally in all directions at the cap or at grade. Examples of braced head conditions include TMP shafts that extend through concrete slabs on grade and TMP caps or shafts that are laterally braced in all directions by the structure they support such as a attached deck built on grade. Free head conditions shall be assumed when TMP are not defined as braced head. Examples of free head conditions are TMP that support wood posts of an elevated deck.
- Assumes 6-inch maximum TMP extension above grade and eccentricity 0.5 inches plus shaft misalignment of 0.35 degrees.
- Capacities include allowance for corrosion for 50-year design life. Sites with high corrosive potential require site-specific engineering review.
- The structural allowable tension capacities were determined by analysis on Helical Foundations without couplings. Where couplings are used, the Helical Foundations are limited by the coupling capacity, by the geotechnical capacities in Table 1 for FS=2.5 and, for Helical Foundations installed at depths less than 12D, by the weight of the soil cone above the helix in accordance with Table 4.



TABLE 3 – INSTALLATION TORQUE REQUIRED TO ACHIEVE EQUIVALENT BEARING CAPACITY TO FOOTERS PRESCRIBED IN IRC TABLE R507.3.1 TO SUPPORT DECKS, BASED ON FOOTING SIZE/TRIBUTARY DECK AREA^{4,5,8,9}

Diameter of Circular Footer ²	Area ^{3,9} under footer ($\pi \cdot r^2$)	For Installation in Q = 1500psf Soil				For Installation in Q = 2000psf Soil			
		Allowable Bearing Capacity ¹	Minimum Torque to get Capacity ^{6,7}			Allowable Bearing Capacity ¹	Minimum Torque to get Capacity ^{6,7}		
			P1 ¹⁰ (at K _t =10)	P2 ¹⁰ (at K _t =10)	P3 ¹⁰ (at K _t =7)		P1 ¹⁰ (at K _t =10)	P2 ¹⁰ (at K _t =10)	P3 ¹⁰ (at K _t =7)
12 in	0.8 sqft	1178 lb	236 ft lb	236 ft lb	337 ft lb	1571 lb	314 ft lb	314 ft lb	449 ft lb
14 in	1.1 sqft	1604 lb	321 ft lb	321 ft lb	458 ft lb	2138 lb	428 ft lb	428 ft lb	611 ft lb
16 in	1.4 sqft	2094 lb	419 ft lb	419 ft lb	598 ft lb	2793 lb	559 ft lb	559 ft lb	798 ft lb
18 in	1.8 sqft	2651 lb	530 ft lb	530 ft lb	757 ft lb	3534 lb	707 ft lb	707 ft lb	1010 ft lb
20 in	2.2 sqft	3273 lb	655 ft lb	655 ft lb	935 ft lb	4363 lb	873 ft lb	873 ft lb	1247 ft lb
22 in	2.6 sqft	3960 lb	792 ft lb	792 ft lb	1131 ft lb	5280 lb	1056 ft lb	1056 ft lb	1508 ft lb
24 in	3.1 sqft	4712 lb	942 ft lb	942 ft lb	1346 ft lb	6283 lb	1257 ft lb	1257 ft lb¹¹	1795 ft lb
26 in	3.7 sqft	5531 lb	1106 ft lb	1106 ft lb	1580 ft lb	7374 lb	Exceeds torque rating	1475 ft lb	2107 ft lb
28 in	4.3 sqft	6414 lb	1283 ft lb	1283 ft lb	1833 ft lb	8552 lb		1710 ft lb	2443 ft lb
30 in	4.9 sqft	7363 lb	Exceeds torque rating	1473 ft lb	2104 ft lb	9818 lb		1964 ft lb	2805 ft lb
32 in	5.6 sqft	8378 lb		1676 ft lb	2394 ft lb	11170 lb		2234 ft lb	3191 ft lb
34 in	6.3 sqft	9458 lb		1892 ft lb	2702 ft lb	12610 lb		Exceeds torque rating	3603 ft lb
36 in	7.1 sqft	10603 lb	2121 ft lb	3029 ft lb	14137 lb	14137 lb	4039 ft lb		

S.1.: 1 inch = 25.4 mm; 1 ft = 305 mm; 1 lb = 4.4 N; 1 psf = 47.9 N/m²; 1 sqft = 0.093 m²; 1 ft lb = 1.4 N m

- Assumes braced head condition. Table 2 gives structural capacity limits for all TMP Helical Foundation Models.
- Applies where IRC Table R507.3.1 prescribes a circular footer of diameter, D (in).
- The area beneath the footer, A_f (sqft) = $\pi [(D/12)/2]^2$. Area may also be applied to square footers. A_f for square footers is the square of the length in feet of the side (length of side in inches/12).
- At a given assumed soil bearing capacity, Q (psf), the footer can support a load P_r (lb) = Q · A_f.
- The tributary deck area that can be supported by the footer, A_t (sqft) = P_r / ([SL or LL]+DL).
- The Helical Foundations have demonstrated an ultimate geotechnical support capacity, P_u = K_t · T, per Section 3.1.1.
- A safety factor of 2 has been applied to the required installation torque tabulated above,
- Loading on Deck tributary area is determined using snow (SL) or live (LL) loads plus a dead load (DL) of 10 psf.
- Use the tabulated Installation Torque, T, for given support conditions, or either formula below:
 - T (ft lb) = $2A_t([SLorLL]+10)/K_t$, based on Tributary Area, A_t.
 - T (ft lb) = $2Q\pi[(D/12)/2]^2/K_t$, based on Soil Cap, Q, and Circular Footer Diameter, D, for circular footers; or, T (ft lb) = $2Q(S/12)^2/K_t$, based on Soil Cap, Q, and Length of Side of Square Footer, S, for square footers.
K_t = Torque-to-capacity ratio (ft⁻¹); D = Circular footer diameter; S = Length of Side of Square Footer; Q = Soil bearing capacity; A_t = Tributary Deck Area.
- Descriptions of Helical Foundation Models P1, P2, and P3 are given in Section 4.0 and Table 1 of this report (applies to all helix diameters).
- Example (corresponding to the table entries highlighted above) – a 24-inch-diameter circular footer tabulated in the IRC has a circular area under the footer of 3.1 square feet. This footer installed on a Q = 2000psf soil will support 6,283 lb (3.1416 x 2000). Using any P2-XX model tabulated, which have a torque correlation factor, K_t =10, would require a torque of 628 ft lb to achieve the required geotechnical bearing capacity. A factor of 2 is applied for safety and the P2-XX is installed using a torque of 1,257 ft lb.

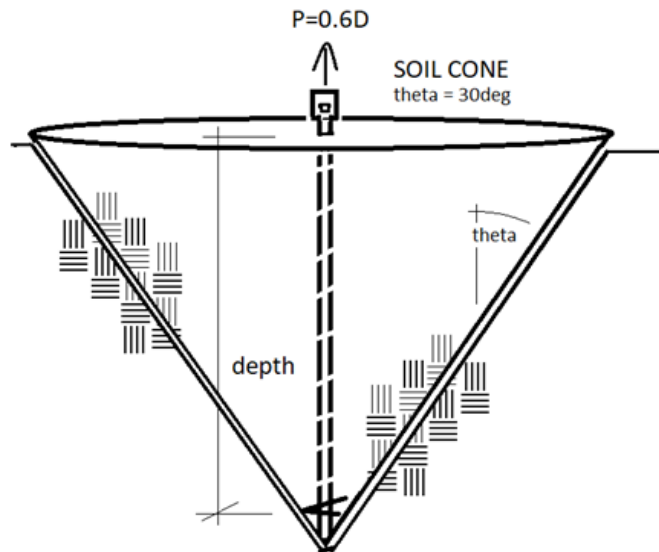

**TABLE 4 – SHALLOW FOUNDATION PULL-OUT RESISTANCE (ALLOWABLE UPLIFT RESISTANCE)
FOR INFLUENCE CONE HAVING A THETA ANGLE OF 30 DEGREES⁴**

Max Allowable Uplift Capacity for Shallow Helix Embedment Depth (<12D) (lbs)							
Helix Depth (ft)	Cone Volume (ft ³)	Soil Dry Unit Weight			Soil Submerged Unit Weight ⁵		
		90 (pcf)	110 (pcf)	125 (pcf)	56 (pcf)	69 (pcf)	78 (pcf)
4	22.3	1,200	1,500	1,700	800	900	1,000
5	43.6	2,400	2,900	3,300	1,500	1,800	2,000
6	75.4	4,100	5,000	5,700	2,500	3,100	3,500
7	119.7	6,500	7,900	9,000	4,000	4,900	5,600
8	178.6	9,600	11,800	13,400	6,000	7,300	8,300
9	254.3	13,700	16,800	19,100	8,600	10,500	11,900
10	348.9	18,800	23,000	-	11,700	14,300	16,300
11	464.4	-	-	-	15,600	19,100	21,700

S.I.: 1 inch = 25.4 mm; 1 ft = 305 mm; 1 lbf = 4.4 N

1. This table is based on the weight of soil above the shallowest helix as depicted in Figure 2. The allowable capacity shall not exceed the structural tension capacity of the assembly given in Table 2 of this report.
2. The allowable hold-down force is independent of the helix diameter and is based on load combination 0.6 x weight of soil.
3. Tabulated values may be interpolated for soil densities between those given. The values do not apply to very loose or saturated soils with lesser densities than those tabulated.
4. The shape of the influence cone is defined by an angle, theta, conservatively assumed to be a maximum of 30 degrees from vertical rather than the more commonly used angle of 45 degrees.
5. Submerged unit weight shall be assumed (water table at grade elevation) unless determined to be otherwise by site-specific investigation.
6. Weight of soil shall be reduced to account for overlapping influence cones where multiple Helical Foundations are used in tension side-by-side when the spacing between foundations is less than the depth of the helix.



[Figure 2 - Soil Cone used for Shallow Pull-Out Resistance]

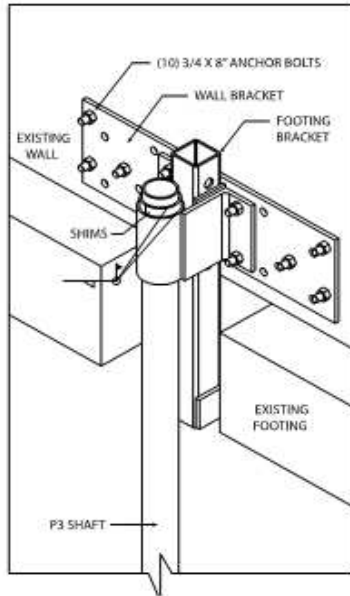

[FIGURE 3A - SM1 underpinning bracket]

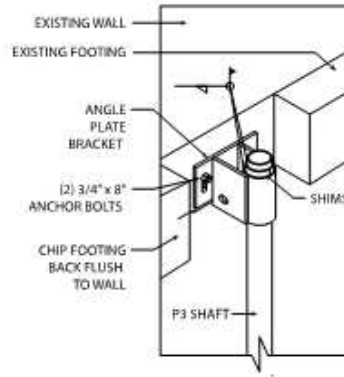
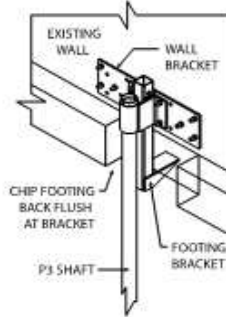

[FIGURE 3B - SM3 underpinning bracket]

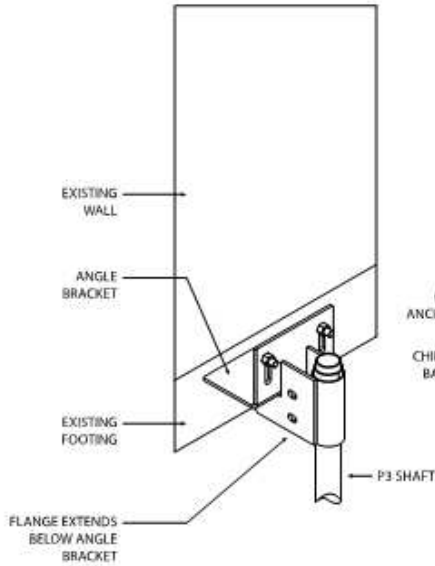
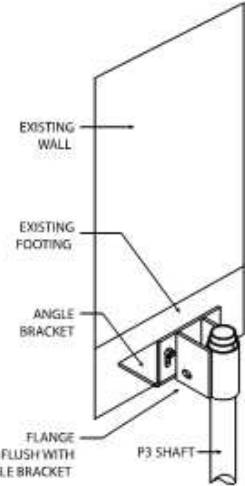

[FIGURE 3C - SM4 underpinning bracket]

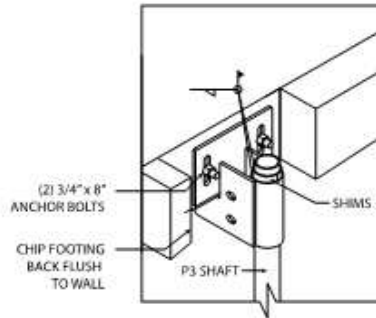

TABLE 5 – HELICAL FOUNDATION UNDERPINNING BRACKET STRUCTURAL CAPACITY

Bracket Type	Allowable Load (lbf) ^{1,2}
SM-3	16,000
SM-4	20,800
SM-1	29,500

S.I.: 1 lbf = 4.4 N

1. Bracket shall be bolted to a concrete foundation in accordance with the manufacturer's instructions. Capacities based on minimum $f'_c = 2,500$ psi concrete compressive strength. Evaluation of foundation to span between brackets is outside the scope of this report.
2. Capacities based on helical foundation shafts fully embedded in firm soils.